

Cable-Extension Position Transducer

Incremental Encoder Output

Ranges: 0-30 inches

Flight/Crash Test Applications • 360° 2-Axis Mount **CE**

MT2E

Specification Summary:

GENERAL

Full Stroke Range..... 0-30 inches, min.
 Output Signalincremental encoder (quadrature) signal
 Accuracy 0.04% full stroke *contact factory for higher accuracy*
 Repeatability..... ± 0.02% of measurement
 Resolution 316 ± 7 pulses per inch (13 ± 1 pulses per mm)
 Measuring CableØ.019-in. nylon-coated stainless steel
 Enclosure Material..... anodized aluminum
 Sensor Cover..... polycarbonate
 Sensoroptical incremental encoder
 Weight..... 0.5 lb. max.

ELECTRICAL

Input Voltage 5 - 26 VDC
 Input Current..... 35 mA, no load
 Output Driverpush-pull, 20 mA source/sink
 Output Voltage..... equal to the input voltage
 Mating Plug..... LEMO FGG.OB.304.CLAD52

MECHANICAL

Measuring Cable Tension Options9, 14 and 33 oz., *see ordering information*
 Maximum Measuring Cable Acceleration..... 136 G's, *see ordering information*

ENVIRONMENTAL

Operating Temperature0° to 70°C



The MT2E is our new encoder-based member to our family of rugged, accurate miniature cable-extension position transducers. The Celesco MT2E features a highly-tensioned heavy-duty measuring cable that was designed for the high-acceleration demands encountered in flight testing and automotive crash tests.

The MT2E was designed with 2-axis 360° rotation in its mounting bracket which allows for fast and simple installation in any direction.

Outline Drawing

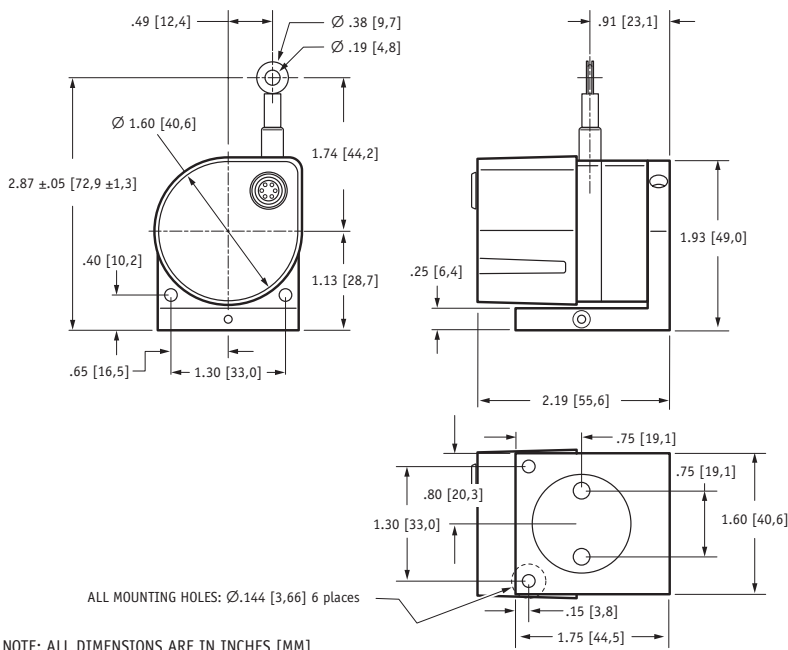

Output Signal

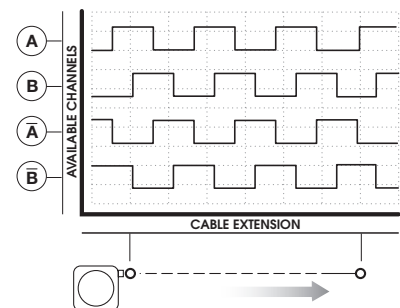

Ordering Information:

Model Number:

MT2E - 30 order code: A - B - **316** - C

Sample Model Number:

MT2E - 30E - 33 - 316 - M1

- R** range: 30 inches
- A** measuring cable termination: eyelet
- B** measuring cable tension: 33 oz. (±6 oz.)
- C** electrical connection: end-mounted connecto

Measuring Cable Termination:

A order code:

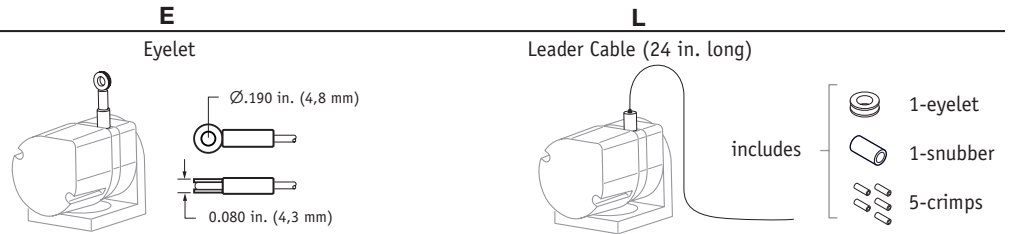

Measuring Cable Tension:

B order code:

	9	14	33
tension:	9 (±2) oz.	14 (±4) oz.	33 (±6) oz.
max. cable acceleration:	99 G's	136 G's	136 G's
min. spring cycle-life:	100,000	75,000	25,000

Electrical Connection:

C order code:

	M1	M2	M3	C1	C2	C3
connection:	end-mount connector	side-mount connector	top-mount connector	end-mount strain relief	side-mount strain relief	top-mount strain relief
available channels:	A, B	A, B	A, B	A, A', B, B'	A, A', B, B'	A, A', B, B'

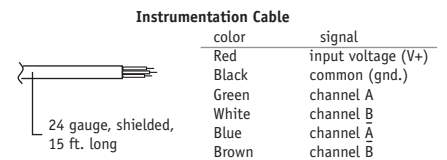
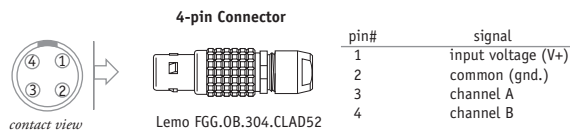
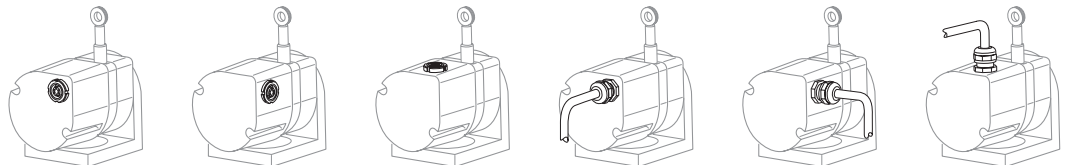

Accessories:

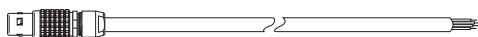

Part No.: 9603957-0015
 Description: 15 ft. long cordset
 includes mating connector and 15 ft., 24 gauge, shielded multiconductor cable

version: 3.0 last updated: August 1, 2006