

Cable-Extension Position Transducer

Incremental Encoder Output
Ranges: 0-75 to 0-550 inches
Industrial Grade

PT9150

Specification Summary:

GENERAL

Full Stroke Range Options—*on this datasheet* 0-75 to 0-550 inches
 Output Signal incremental encoder (quadrature)
 Output Driver Options TTL/CMOS, open collector or line driver
 Accuracy 0.04% full stroke *contact factory for higher accuracy*
 Repeatability $\pm 0.02\%$ full stroke $\pm 1/2$ pulse max.
 Resolution Options 10 to 250 pulses per inch
 Measuring Cable Options nylon-coated stainless steel or thermoplastic
 Enclosure Material powder-painted aluminum or stainless steel
 Sensor optical incremental encoder
 Maximum Retraction Acceleration *see ordering information*
 Maximum Velocity *see ordering information*
 Weight, Aluminum (Stainless Steel) Enclosure 8 lbs. (16 lbs.) max.

ELECTRICAL

Input Voltage *see ordering information*
 Input Current *see ordering information*

ENVIRONMENTAL

Enclosure NEMA 4/4X/6, IP 67/68
 Operating Temperature 0° to 160°F (-17° to 71°C)
 Vibration up to 10 G's to 2000 Hz maximum

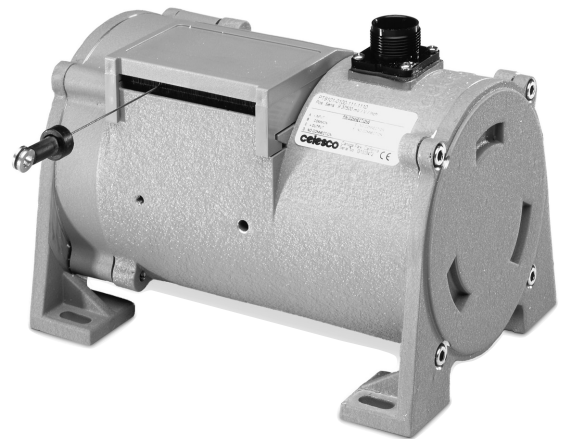

With its incremental optical encoder and industrial design this rugged transducer provides the highest accuracy and longest life of any measurement device of its kind. This model is available in a wide variety of resolutions and output stages to fit virtually any requirement.

It can measure up to 1700", yet when its cable is retracted it is only 6" long. Its small size and low-cost-to-measurement ratio offers remarkable flexibility and value.

Fig. 1 – Outline Drawing (18 oz. cable tension only)

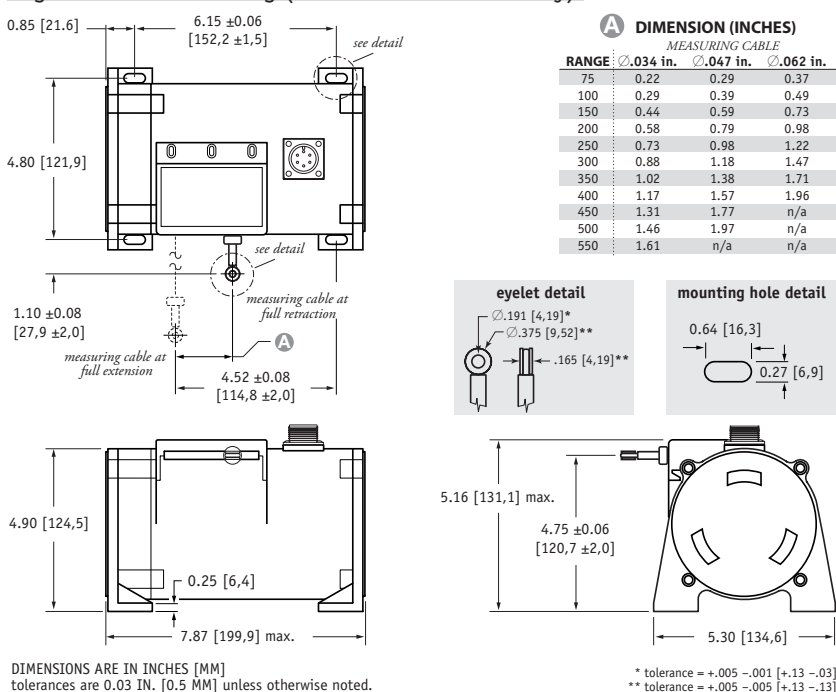

Output Signal

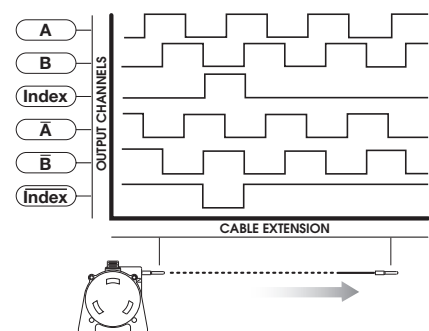

Ordering Information:

Model Number:

PT9150- _____ - _____ - _____ - _____ - _____ - _____ **0**
order code: **R** **A** **B** **C** **D** **E** **F** **G**

Sample Model Number:

PT9150 - 0500 - 111 - 1110

- R** range: 500 inches
- A** enclosure/cable tension: aluminum/18 oz.
- B** measuring cable: .034 nylon-coated stainless
- C** cable exit: front
- D** output signal: TTL/CMOS driver
- E** resolution: 100 ±2 pulses per inch
- F** electrical connection: 6-pin plastic connector

Full Stroke Range:

..... **english ranges**

R order code:	0075	0100	0150	0200	0250	0300	0350	0400	0450*	0500*	0550*
full stroke range, min:	75 in.	100 in.	150 in.	200 in.	250 in.	300 in.	350 in.	400 in.	450 in.	500 in.	550 in.

..... **metric ranges**

R order code:	2500	3750	5000	6250	7500	8750	10000	11250	12500*	13750*
full stroke range, min:	2500 mm	3750 mm	5000 mm	6250 mm	7500 mm	8750 mm	10000 mm	11250 mm	12500 mm	13750 mm

* - 36 oz. cable tension strongly recommended

Enclosure Material and Measuring Cable Tension:

A order code:	1	3	2	4
tension (±30%):	18 oz.		36 oz.	
enclosure material:	<i>powder-painted aluminum</i>	<i>303 stainless steel</i>	<i>powder-painted aluminum</i>	<i>303 stainless steel</i>
max. acceleration:	1 G	.33 G	5 G	2 G
max. velocity:	60 inches/sec	20 inches/sec	200 inches/sec	80 inches/sec

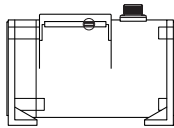

standard housing
see fig 1.

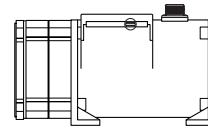

dual-spring housing
see fig 2.

Measuring Cable:

B order code:	1	2	3
	∅.034-inch nylon-coated stainless steel <i>available in all ranges</i>	∅.047-inch stainless steel <i>all ranges up to 500 in. [12500 mm]</i>	∅.062-inch thermoplastic <i>all ranges up to 400 in. [10000 mm]</i>

Cable Exit:

C order code:	1	2	3	4
	front	top	back	down

Ordering Information:

Output Signals:

① order code:	1	2	3	4
output driver:	TTL - CMOS	Open Collector	5 V - Line Driver	Universal Line Driver
Input voltage (V+):	4.5...13.2 Vdc	10.8...26.4 Vdc	5 Vdc	5...30 VDC
Sink current:	20 mA max.	20 mA max.	20 mA max.	20 mA max.
Input current:	80 mA max.	80 mA max.	150 mA max.	100 mA max, no load

Resolution:

② order code:	1	2	3	4
english ranges:	100 ±2 pulses per in.	200 ±4 pulses per in.	250 ±5 pulses per in.	10 ±0.2 pulses per in.
metric ranges:	5 ±0,1 pulses per mm	10 ±0,2 pulses per mm	12,5 ±0,25 pulses per mm	0,5 ±0,01 pulses per mm

Electrical Connection:

③ order code:	1	2	3	4																																																																											
	6-pin plastic connector with mating plug IP 67, NEMA 4X*,6	25-ft. instrumentation cable 24 AWG, shielded IP 67, NEMA 6	18-pin plastic connector with mating plug IP 65, NEMA 4	6-pin metal connector with mating plug IP 67, NEMA 6																																																																											
	.30 - .39 in. [8 - 10 mm] cable dia. 16 AWG max conductor size connector: MS3102E-14S-6P mating plug: MS3106E-14S-6S	25 ft. x 0.2-in. dia. [7,5 M x 5 mm dia.] 24 AWG, shielded	.26 - .30 in. [6,6 - 7,6 mm] cable dia. 20 - 24 AWG conductor size connector: Conxall 14282-18PG-300-K mating plug: Conxall 13282-18SG-326-K	3/8-in. [9 mm] max cable dia. 16 AWG max conductor size connector: MS3102E-14S-6P mating plug: MS3106E-14S-6S																																																																											
	6-pin mating plug:	18-pin mating plug:	25-ft. instrumentation cable:																																																																												
	<table border="1"> <thead> <tr> <th>pin</th> <th>TTL/CMOS Open Collector</th> <th>5 V Line Driver Universal Line Driver</th> </tr> </thead> <tbody> <tr> <td>A</td> <td>input voltage</td> <td>input voltage</td> </tr> <tr> <td>B</td> <td>common</td> <td>common</td> </tr> <tr> <td>C</td> <td>channel A</td> <td>channel A</td> </tr> <tr> <td>D</td> <td>channel B</td> <td>channel B</td> </tr> <tr> <td>E</td> <td>-</td> <td>channel A'</td> </tr> <tr> <td>F</td> <td>-</td> <td>channel B'</td> </tr> </tbody> </table>	pin	TTL/CMOS Open Collector	5 V Line Driver Universal Line Driver	A	input voltage	input voltage	B	common	common	C	channel A	channel A	D	channel B	channel B	E	-	channel A'	F	-	channel B'	<table border="1"> <thead> <tr> <th>pin</th> <th>TTL/CMOS Open Collector</th> <th>5 V Line Driver Universal Line Driver</th> </tr> </thead> <tbody> <tr> <td>1</td> <td>input voltage</td> <td>input voltage</td> </tr> <tr> <td>2</td> <td>common</td> <td>common</td> </tr> <tr> <td>3</td> <td>channel B</td> <td>channel B</td> </tr> <tr> <td>6</td> <td>channel A</td> <td>channel A</td> </tr> <tr> <td>7</td> <td>-</td> <td>index</td> </tr> <tr> <td>11</td> <td>-</td> <td>channel B'</td> </tr> <tr> <td>12</td> <td>-</td> <td>channel A'</td> </tr> <tr> <td>15</td> <td>-</td> <td>index'</td> </tr> </tbody> </table>	pin	TTL/CMOS Open Collector	5 V Line Driver Universal Line Driver	1	input voltage	input voltage	2	common	common	3	channel B	channel B	6	channel A	channel A	7	-	index	11	-	channel B'	12	-	channel A'	15	-	index'	<table border="1"> <thead> <tr> <th>color</th> <th>TTL/CMOS Open Collector</th> <th>5 V Line Driver Universal Line Driver</th> </tr> </thead> <tbody> <tr> <td>red</td> <td>input voltage</td> <td>input voltage</td> </tr> <tr> <td>black</td> <td>common</td> <td>common</td> </tr> <tr> <td>green</td> <td>channel A</td> <td>channel A</td> </tr> <tr> <td>white</td> <td>channel B</td> <td>channel B</td> </tr> <tr> <td>blue</td> <td>-</td> <td>channel A'</td> </tr> <tr> <td>brown</td> <td>-</td> <td>channel B'</td> </tr> <tr> <td>yellow</td> <td>-</td> <td>index</td> </tr> <tr> <td>orange</td> <td>-</td> <td>index'</td> </tr> </tbody> </table>		color	TTL/CMOS Open Collector	5 V Line Driver Universal Line Driver	red	input voltage	input voltage	black	common	common	green	channel A	channel A	white	channel B	channel B	blue	-	channel A'	brown	-	channel B'	yellow	-	index	orange	-	index'
pin	TTL/CMOS Open Collector	5 V Line Driver Universal Line Driver																																																																													
A	input voltage	input voltage																																																																													
B	common	common																																																																													
C	channel A	channel A																																																																													
D	channel B	channel B																																																																													
E	-	channel A'																																																																													
F	-	channel B'																																																																													
pin	TTL/CMOS Open Collector	5 V Line Driver Universal Line Driver																																																																													
1	input voltage	input voltage																																																																													
2	common	common																																																																													
3	channel B	channel B																																																																													
6	channel A	channel A																																																																													
7	-	index																																																																													
11	-	channel B'																																																																													
12	-	channel A'																																																																													
15	-	index'																																																																													
color	TTL/CMOS Open Collector	5 V Line Driver Universal Line Driver																																																																													
red	input voltage	input voltage																																																																													
black	common	common																																																																													
green	channel A	channel A																																																																													
white	channel B	channel B																																																																													
blue	-	channel A'																																																																													
brown	-	channel B'																																																																													
yellow	-	index																																																																													
orange	-	index'																																																																													

*-applies to stainless steel enclosure only.

PT9150 • Cable-Extension Transducer: Incremental Encoder Output Signal

Fig. 2 – Outline Drawing (36 oz. cable tension only)

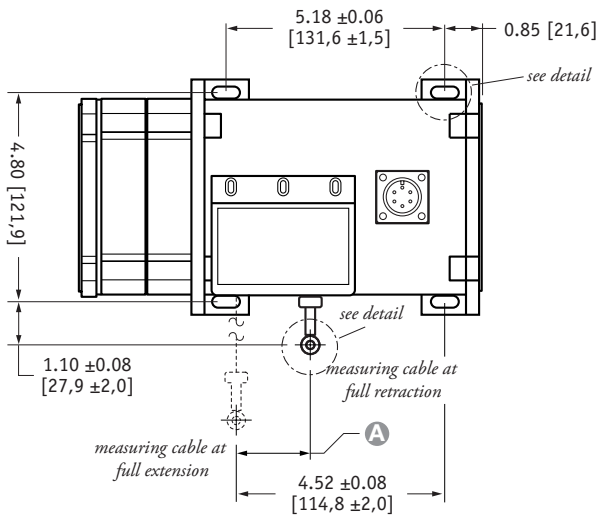

A DIMENSION (INCHES)

MEASURING CABLE

RANGE	∅.034 in.	∅.047 in.	∅.062 in.
75	0.22	0.29	0.37
100	0.29	0.39	0.49
150	0.44	0.59	0.73
200	0.58	0.79	0.98
250	0.73	0.98	1.22
300	0.88	1.18	1.47
350	1.02	1.38	1.71
400	1.17	1.57	1.96
450	1.31	1.77	n/a
500	1.46	1.97	n/a
550	1.61	n/a	n/a

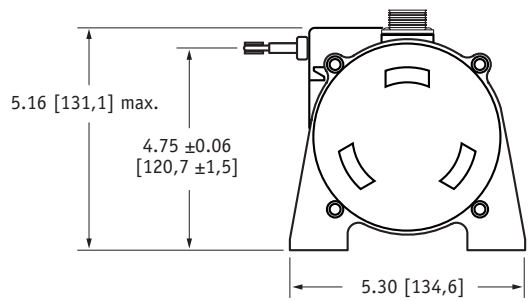
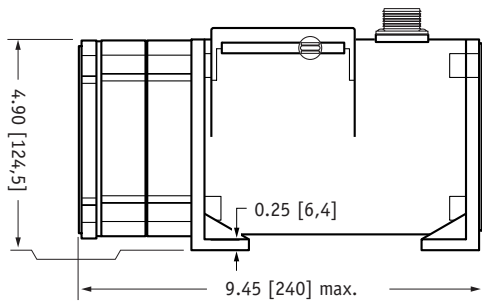
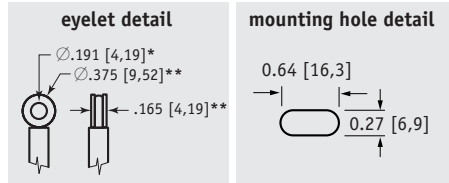

DIMENSIONS ARE IN INCHES [MM]
tolerances are 0.03 IN. [0.5 MM] unless otherwise noted.

* tolerance = +.005 - .001 [+ .13 - .03]
** tolerance = +.005 - .005 [+ .13 - .13]