

ITEM NO.	PART NUMBER	DESCRIPTION	QTY
15	SEE TABLE 1	SUBASSY,MAIN SHAFT/SPRING PIN	1
14	SEE TABLE 1	WRENCH, ENCODER MOUNTING SCREWS	1
13	9000040-0004	WRENCH,HEX,3/16 INCH	1
12	SEE TABLE 2	WRENCH, COUPLING	1
11	9677458-0000	GASKET,RUBBER,PT5A	1
10	SEE TABLE 1	ENCODER MOUNTING SCREWS	AR
9	SEE TABLE 2	FLEXIBLE COUPLING	1
8	9030000-0013	PLUG,HOLE,NYLON,BLACK,3/4 DIA	1
7	9650615-0000	WASHER,MTL-RUBBER,PER 650615	2
6	9650444-0258	CSCR CRES 0.250-20X2.75 SKT HD	2
5	9007121-4406	MSCR CRES 0.112-40X.31 XRSPNH	4
4	9000320-0006	GASKET,FLANGED CONN, 14 SHELL	1
3	9676751-0000	COVER, CONNECTOR, CRES	1
2	9678435-0000	HOUSING, PT5600 SERIES	
1	SEE TABLE 1	ENCODER MOUNTING PLATE	1

REVISIONS			
REV.	DESCRIPTION	DATE	APPROVED
C	SEE DCN: 8232	06/30/2011	MSK

ASSEMBLE THIS SECTION PER PS-135

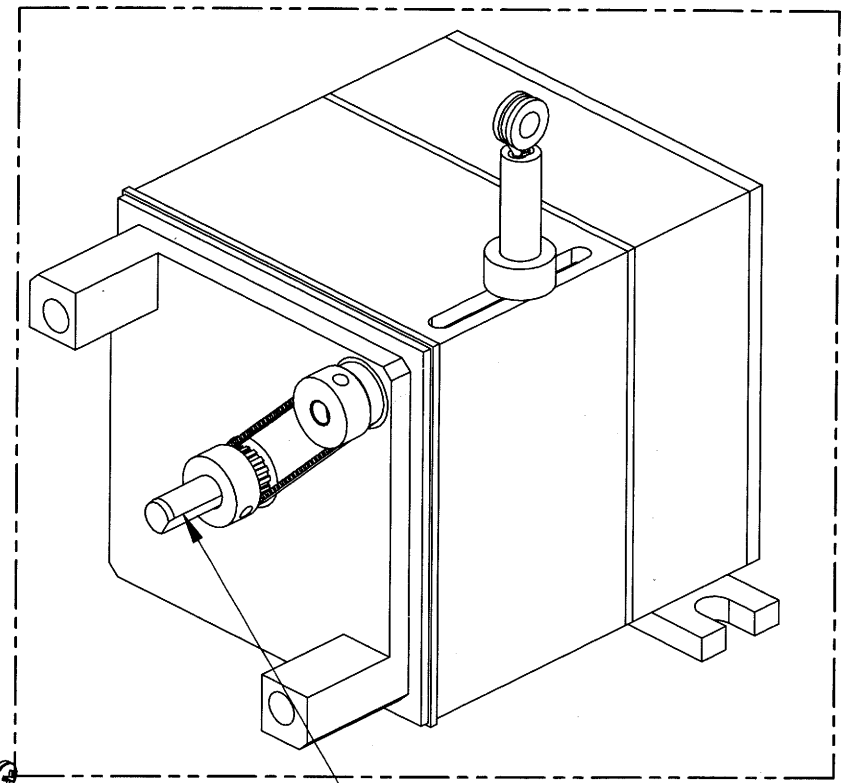
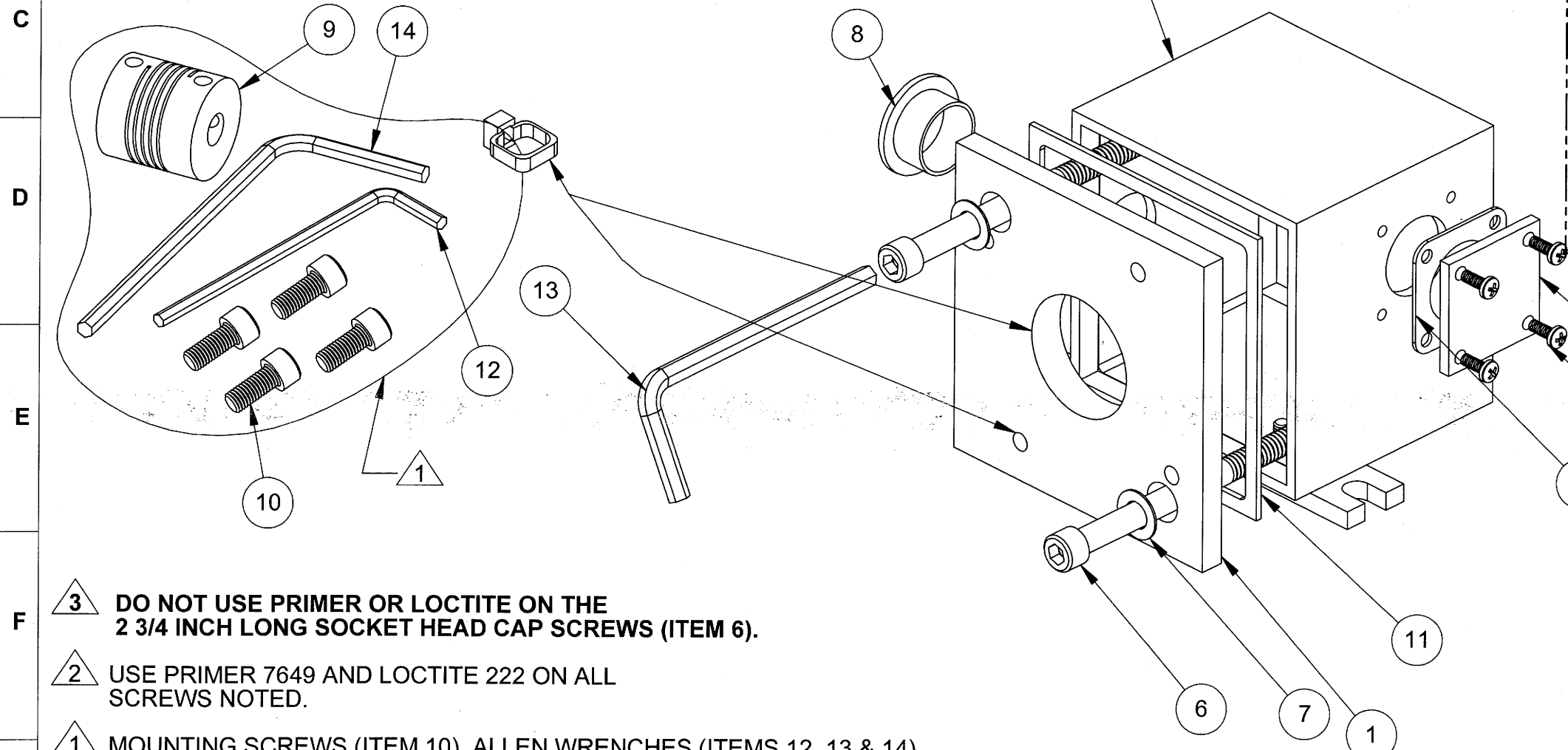

ORIGINAL

- 3** DO NOT USE PRIMER OR LOCTITE ON THE 2 3/4 INCH LONG SOCKET HEAD CAP SCREWS (ITEM 6).
- 2** USE PRIMER 7649 AND LOCTITE 222 ON ALL SCREWS NOTED.
- 1** MOUNTING SCREWS (ITEM 10), ALLEN WRENCHES (ITEMS 12, 13 & 14), AND FLEXIBLE COUPLING (ITEM 9), TO BE PACKAGED IN A CLEAR PLASTIC BAG AND ATTACHED TO THE END PLATE OF THE TRANSDUCER. IF PT5600 IS ASSEMBLED WITH AN ENCODER, PACKAGE ONLY HEX WRENCH (ITEM 14), IN CLEAR PLASTIC BAG.

NOTES: UNLESS OTHERWISE SPECIFIED

INFORMATION AND DATA SET FORTH HEREIN ARE DISCLOSED IN CONFIDENCE AND ARE PROPRIETARY TO AND THE PROPERTY OF CELESCO TRANSDUCER PRODUCTS INC. AND SHALL NOT BE USED, DUPLICATED, DISCLOSED OR TRANSFERRED, IN WHOLE OR IN PART, FOR ANY PURPOSE, WITHOUT THE EXPRESS PRIOR WRITTEN CONSENT OF CELESCO TRANSDUCER PRODUCTS INC.

THIRD ANGLE PROJECTION				celesco 20630 Plummer St Chatsworth, CA. 91311 Tel:(818)701-2750 Fax:(818)701-2799 www.celesco.com	
APPROVALS DRAWN A.ALVAREZ 02/06/09 CHKD <i>g3</i> 7/1/11		DATE 7/1/11		TITLE ASSEMBLY DRAWING PT5600	
DO NOT SCALE DRAWING		SIZE B	CODE IDENT. NO 52158	DWG. NO. PS-161	REV C
SCALE: 4:1			SHEET 1 OF 3		

A
B
C
D
E
F
G

TABLE 1					
MOUNTING OPTION	F01	F02	S01	S02	S04
ENCODER MOUNTING PLATE	9678618-0000	9678615-0000	9679073-0000	9679402-0000	9678617-0000
ENCODER MOUNTING SCREWS	9650444-0052	9650444-0054	9650444-0237	96560444-0009	9650444-0030
HEX WRENCHES	9000040-0003		NOT REQUIRED		
MAIN SHAFT SUBASSY	9603893-0000	9679138-0000	9678897-0000	9603983-0000	9603983-0000

TABLE 2		
ENCODER SHAFT DIAMETER	FLEXIBLE COUPLING	WRENCH
Ø0.375	9000400-0120	9000040-0017
Ø6MM	9000400-0126	9000040-0016
Ø10MM	9000400-0143	9000040-0021

ORIGINAL

INFORMATION AND DATA SET FORTH HEREIN ARE DISCLOSED IN CONFIDENCE AND ARE PROPRIETARY TO AND THE PROPERTY OF CELESCO TRANSDUCER PRODUCTS INC. AND SHALL NOT BE USED, DUPLICATED, DISCLOSED OR TRANSFERRED, IN WHOLE OR IN PART, FOR ANY PURPOSE, WITHOUT THE EXPRESS PRIOR WRITTEN CONSENT OF CELESCO TRANSDUCER PRODUCTS INC.

THIRD ANGLE PROJECTION

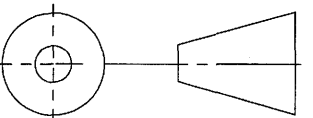

celesco 20630 Plummer St
Chatsworth, CA. 91311
Tel:(818)701-2750 Fax:(818)701-2799
www.celesco.com

Transducer Products Inc.

TITLE
ASSEMBLY DRAWING
PT5600

APPROVALS	DATE	SIZE	CODE IDENT. NO	DWG. NO.	REV
DRAWN A.ALVAREZ	02/06/09	B	52158	PS-161	C
CHKD <i>[Signature]</i>	<i>[Signature]</i>	DO NOT SCALE DRAWING		SCALE: 4:1	SHEET 2 OF 3



DRAWING CHANGE NOTICE

DRAWING NO. **PS-161** REV. **C**

SHEET 3 OF 3

DISPOSITION OF PARTS	USE AS IS	MUST CONFORM	PART NAME ASSEMBLY DRAWING			DCN NO. 8232		
IN FABRICATION		X	ENGINEERING APPROVAL			COPIES TO	YES	NO
IN STOCK		X		SIGNATURE	DATE	ENGINEERING	X	
BOXED PARTS		X	PREPARED BY	MSK	06/30/2011	INSPECTION	X	
IN ASSEMBLIES		X	CHECKED BY	<i>[Signature]</i>	7/1/11	PLANNING	X	
IN BOND		X	APPROVED	<i>[Signature]</i>	7/1/11	PRODUCTION	X	
CUSTOMER REWORK		X	GEN MGR	X	X	PURCHASING	X	
			DCR NO. (IF APPLICABLE)	0000		QMR	X	
						SALES	X	

CHANGE NO	REVISED OR CHANGED FROM	SHEET / ZONE	ADDED OR CHANGED TO
1	WAS: PS-161, REV-B		IS: PS-161, REV-C
2	OLD BULKHEAD PLATE, 9679584-0000	SHT 1 /B8	IS NOW: 9679885-0000
3	DELETE SPACERS, 9013143-GE10	SHT 1 /C7	
4	MOVED FLEXIBLE COUPLING, ITEM 9 FROM ISO VIEW	SHT 1 /C1	MOVED FLEXIBLE COUPLING TO BE CONTAINED IN PLASTIC BAG
5	NOTE 1 WAS: MOUNTING SCREWS AND ALLEN WRENCHES, ITEMS 10,12,13, AND 14 TO BE PACKAGED IN A CLEAR PLASTIC BAG AND ATTACHED TO THE END PLATE OF THE TRANSDUCER, OR SIMILAR PART. IF PT5600 IS ASSEMBLED WITH AN ENCODER, PACKAGE ONLY ITEM 14 IN CLEAR PLASTIC BAG.		NOTE 1 IS NOW: MOUNTING SCREWS (ITEM 10), ALLEN WRENCHES (ITEMS 12, 13 & 14), AND FLEXIBLE COUPLING (ITEM 9), TO BE PACKAGED IN A CLEAR PLASTIC BAG AND ATTACHED TO THE END PLATE OF THE TRANSDUCER. IF PT5600 IS ASSEMBLED WITH AN ENCODER, PACKAGE ONLY HEX WRENCH (ITEM 14), IN CLEAR PLASTIC BAG.
6	ITEM 6, END PLATE MOUNTING SCREWS WERE: 9650444-0219		SCREWS ARE NOW: 9650444-0258

NOTES
 CHANGE 2, 3, AND 4: UPDATE TO CURRENT PARTS
 CHANGES 3 AND 4: THE PLACEMENT OF THE FLEXIBLE COUPLING WAS NOT CLEAR. IT WAS SHOWN TO BE MOUNTED TO THE MAIN SHAFT, BUT MADE MORE SENSE TO BE INCLUDED IN THE CLEAR PLASTIC BAG ATTACHED TO THE MOUNTING PLATE. THIS WOULD MAKE IT CONSISTANT WITH THE PROCEDURE USED ON THE PT9600.

REMARKS: