

TABLE I

PT5AV GEARS			POTENTIOMETER OPTIONS			
RANGE	POT GEAR	MAIN SHAFT GEAR	500 Ω POT	1K Ω POT	5K Ω POT	10K Ω POT
10	9000440-0010	9678770-0054	500 Ω, 1 TURN 9083000-0052	1K Ω, 1 TURN 9083000-0025	5K Ω, 1 TURN 9080000-0001	10K Ω, 1 TURN 9083000-0003
15	9678770-0085	9678770-0043				
20	9678770-0090	9000440-0037				
25	9678770-0100	9000400-0034				
30	9000440-0031	9678770-0100				
40	9000440-0009	9678770-0065	500 Ω, 5 TURN 9085000-0004	1K Ω, 5 TURN 9085000-0011	5K Ω, 5 TURN 9085000-0013	10K Ω, 5 TURN 9085000-0001
50	9678770-0054	9678770-0070				
60	9000440-0017	9678770-0080				
80	9000440-0024	9678770-0085				
100	9678770-0085	9000440-0033				
125	9000440-0034	9678770-0100	500 Ω, 10 TURN 9085000-0003	1K Ω, 10 TURN 9085000-0006	5K Ω, 10 TURN 9085000-0010	10K Ω, 10 TURN 9085000-0002
150	9678770-0085	9678770-0043				
200	9678770-0090	9000440-0037				
250	9678770-0100	9000440-0034				

REVISIONS			
REV.	DESCRIPTION	DATE	APPROVED
E	SEE DCN: 8000	3/23/2011	

- C**
- D** 4 BUILD PER PS-135 FOR DETAILS NOT SHOWN ON THIS DRAWING.
- 3 ORIENT GEARS AS SHOWN.
- USE LOCTITE 222.
- USE LOCTITE PRIMER 7649, ALLOW TO DRY.
- E** **NOTES: UNLESS OTHERWISE SPECIFIED**

FOR METAL GEARS ONLY. FOR PLASTIC GEARS, APPLY 1 DROP OF LOCTITE 425 TO THREADS OF GEAR. INSERT SET SCREW AND TIGHTEN 1/4 - 1/2 TURN PAST INITIAL CONTACT.

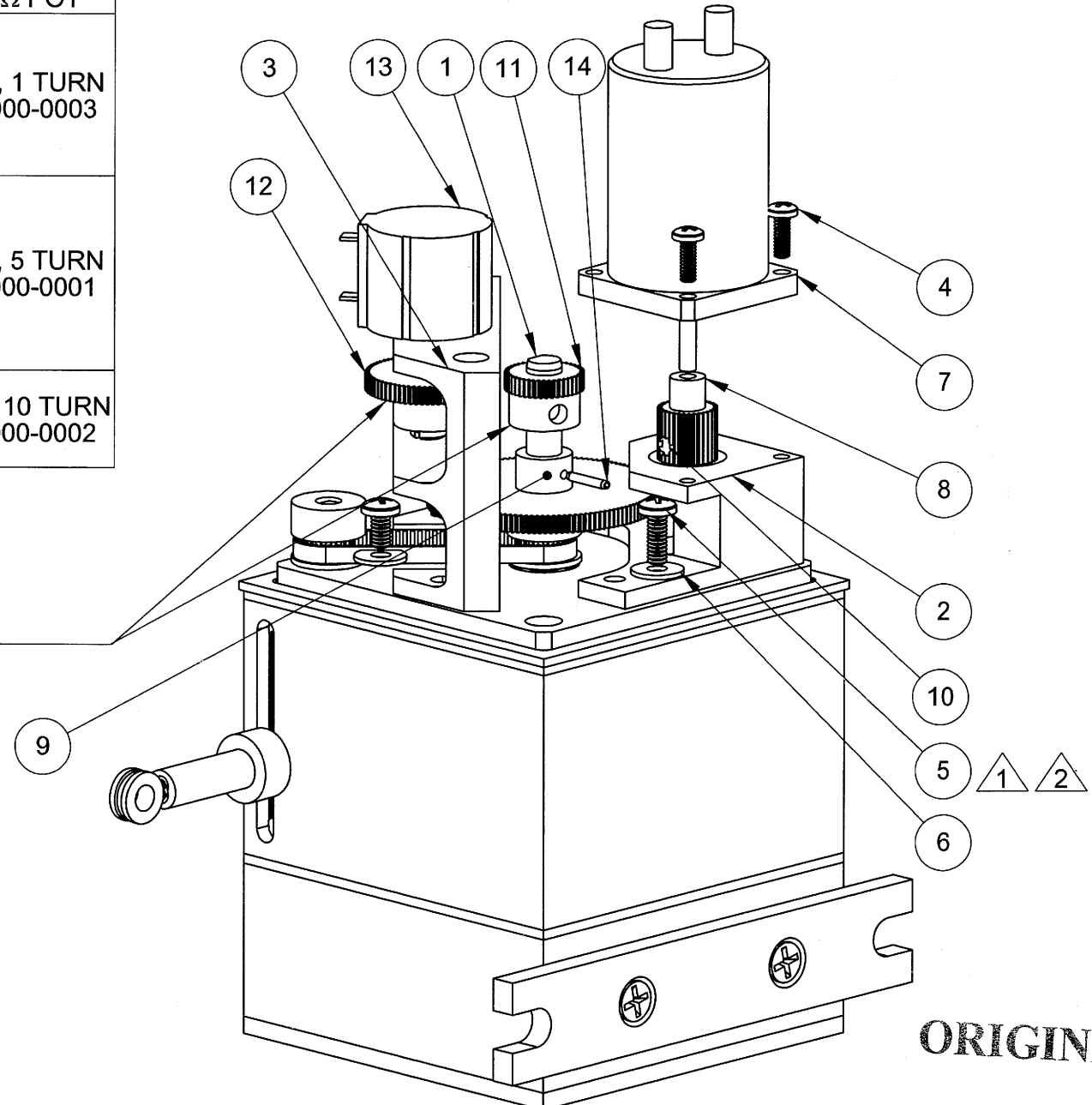

14	9015010-0013	PIN, SPRING, 1/16 X 3/8 LONG	1
13	SEE TABLE 1	POTENTIOMETER OPTIONS	1
12	SEE TABLE 1	GEAR, 80 PITCH, POT SHAFT	1
11	SEE TABLE 1	GEAR, 80 PITCH, MAIN SHAFT	1
10	9000440-0033	GEAR, 80 PITCH, 32 TEETH, 0.25 DIA	1
9	9670165-0000	GEAR, 80 PITCH, 130 TEETH, Ø.25	1
8	9673658-0000	BUSHING, TACH, NYLN, 0.12ID	1
7	9000930-0001	GENERATOR, DC 7V/1000 RPM	1
6	9003101-6003	WASHER, 0.141X.375X.032THK	2
5	9007121-6307	MSCR, CRES, #6-32 X .375 XRSPNH	2
4	9650444-0092	MSCR, CRES, .112-40X.31 PNHD	3
3	9679891-0000	BRACKET, POT, PT5AV	1
2	9679892-0000	BRACKET, TACH, PT5AV	1
1	9604265-0000	SUBASSY, MAIN SHAFT/SPRING PIN, PT5AV	1
ITEM NO.	PART NUMBER	DESCRIPTION	QTY.

INFORMATION AND DATA SET FORTH HEREIN ARE DISCLOSED IN CONFIDENCE AND ARE PROPRIETARY TO AND THE PROPERTY OF CELESCO TRANSDUCER PRODUCTS INC. AND SHALL NOT BE USED, DUPLICATED, DISCLOSED OR TRANSFERRED, IN WHOLE OR IN PART, FOR ANY PURPOSE, WITHOUT THE EXPRESS PRIOR WRITTEN CONSENT OF CELESCO TRANSDUCER PRODUCTS INC.

THIRD ANGLE PROJECTION

celesco 20630 Plummer St
Chatsworth, CA, 91311
Tel: (818) 701-2750 Fax: (818) 701-2799
www.celesco.com

**ASSEMBLY DRAWING
PT5AV SERIES**

APPROVALS	DATE	SIZE	CODE IDENT. NO	DWG. NO.	REV
DRAWN A. ALVAREZ	10/25/01	B	52158	PS-60	E
CHKD	3/23/11	DO NOT SCALE DRAWING		SCALE: 1:1	SHEET 1 OF 3

PT5AV					
	POTENTIOMETER			TACHOMETER	
A	CCW (3)	CW (1)	S (2)	+ OUT	- OUT
	6-PIN CONNECTOR	PIN A	PIN B	PIN C	PIN E PIN F
	INSTRUMENTATION CABLE	RED	BLACK	GREEN	WHITE BROWN

REVISIONS			
REV.	DESCRIPTION	DATE	APPROVED
-	See Sheet 1	-	-

B
C
D
E

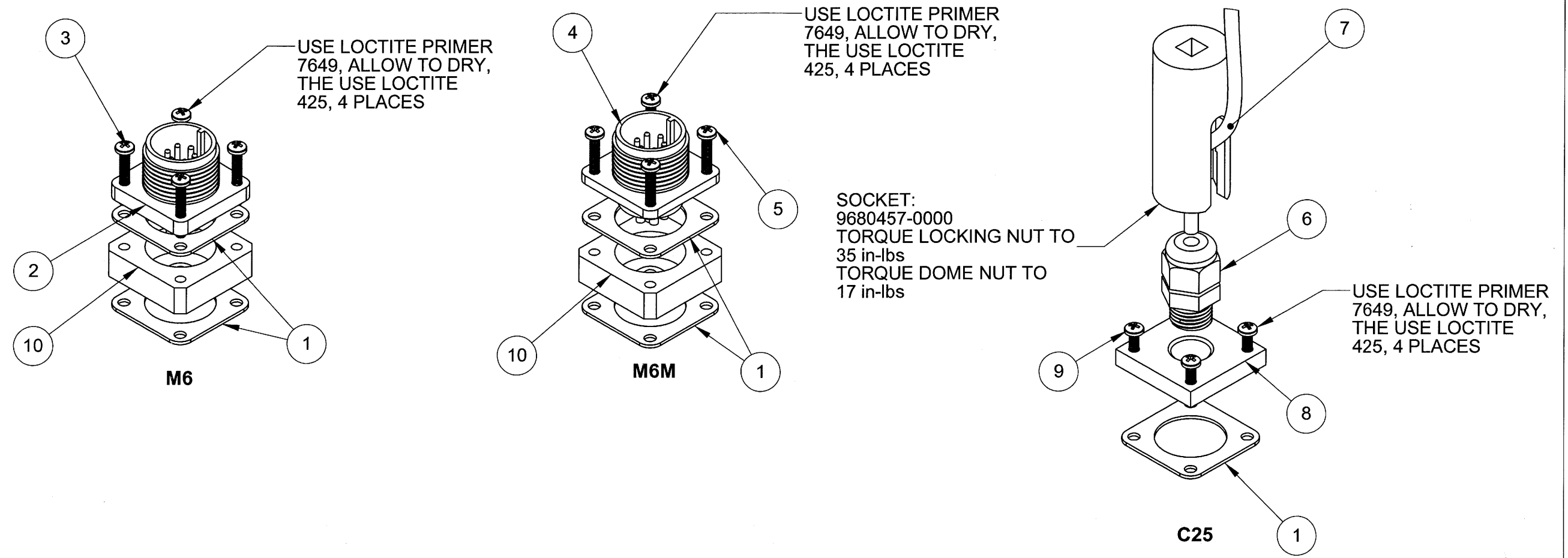

ORIGINAL

F	10	9679565-0000	BLOCK,CONNECTOR,PT5AV	1
	9	9650444-0050	MSCR CRES #4-40X.50 XRSPNH	4
	8	9670137-0000	ADAPTER,UNDERWATER CABLE, ALUM	1
	7	9000141-0026	CABLE,6COND,24GA,PER 650464	25 ft
	6	9032000-0015	STRAIN RELIEF, LIQUID TIGHT, GRAY	1
	5	9007121-440C	MSCR CRES 0.112-40X0.68 XRSPNH	4
	4	9035810-0001	CONN,RCPT,BOX-MTG,14SHELL,6PIN,METAL	1
	3	9650444-0121	MSCR CRES #4-40 X .75 XRSPNHD	4
G	2	9035830-0001	CONN,RCPT,BOX-MTG,14SHELL,6PIN,NYLON	1
	1	9000320-0006	RUBBER GASKET, FLANGED CONN	AR
	ITEM NO.	PART NUMBER	DESCRIPTION	QTY

CONNECTOR OPTIONS BILL OF MATERIALS REFER TO TABLE 2 FOR MATING CONNECTORS

TABLE 2		
MATING CONNECTOR OPTIONS		
CODE	ITEM NO.	MATING CONNECTOR
M6	②	9036830-0001
M6M	④	9036810-0001

INFORMATION AND DATA SET FORTH HEREIN ARE DISCLOSED IN CONFIDENCE AND ARE PROPRIETARY TO AND THE PROPERTY OF CELESCO TRANSDUCER PRODUCTS INC. AND SHALL NOT BE USED, DUPLICATED, DISCLOSED OR TRANSFERRED, IN WHOLE OR IN PART, FOR ANY PURPOSE, WITHOUT THE EXPRESS PRIOR WRITTEN CONSENT OF CELESCO TRANSDUCER PRODUCTS INC.

THIRD ANGLE PROJECTION

celesco 20630 Plummer St
Chatsworth, CA. 91311
Tel:(818)701-2750 Fax:(818)701-2799
www.celesco.com

Transducer Products Inc.

TITLE
ASSEMBLY DRAWING
PT5AV SERIES

APPROVALS	DATE	SIZE	CODE IDENT. NO	DWG. NO.	REV
DRAWN A. ALVAREZ	10/25/01	B	52158	PS-60	E
CHKD MSK	3/23/11	SCALE: 1:1		SHEET 2 OF 3	

DO NOT SCALE DRAWING

