

REVISIONS			
REV.	DESCRIPTION	DATE	APPROVED
A	SEE DCN: 7342	2/1/2010	

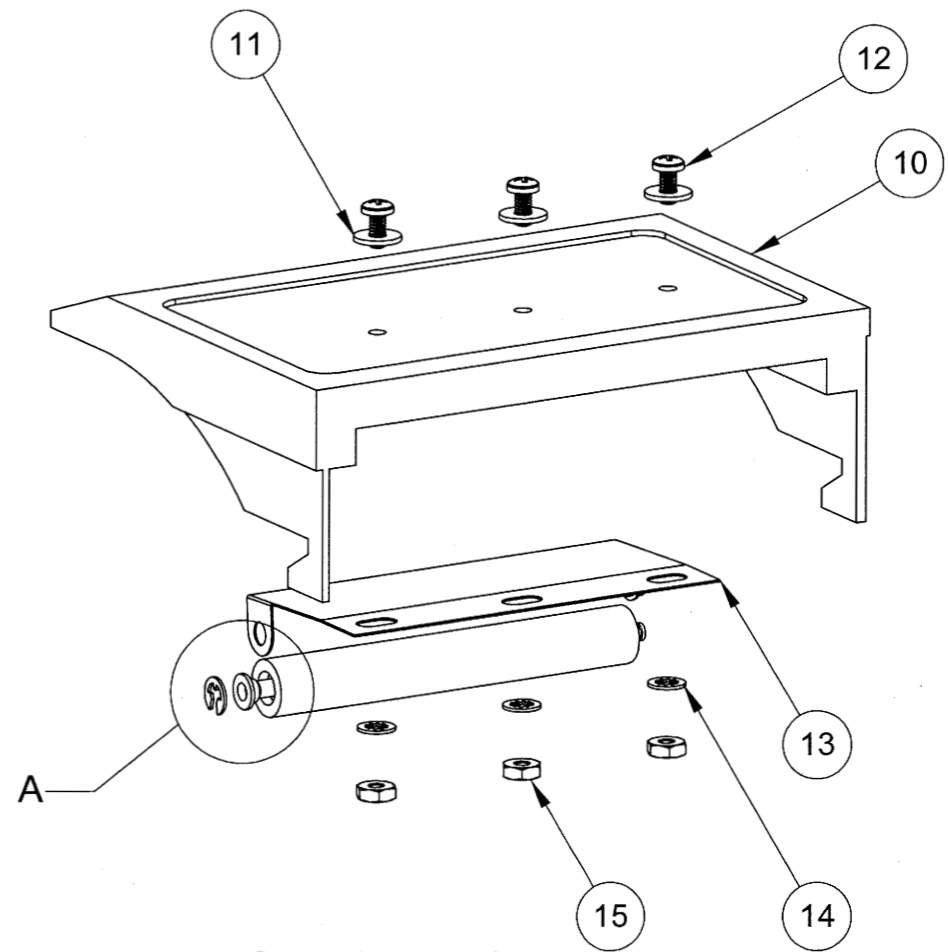

E	18	9000460-0013	RETAINING RING,EXTERNAL,0.094 DIA	2
	17	9679714-0000	BUSHING,FLANGED,SHAFT,BRONZE	2
	16	9679713-0000	CABLE TENSION ROLLER	1
	15	9650444-0073	NUT,HEX,CRES,0.086-56	3
	14	9650444-0222	WASHER,LOC,CRES,0.086 INT TOOTH	3
	13	9679716-0000	CABLE TENSION SPRING	1
	12	9650444-0070	MSCR,CRES,0.086-56 X .19 XRSPNH	3
	11	9650444-0071	WASHER,FLAT,CRES,0.086 ID	3
F	10	9679799-0000	COVER,CABLE,CRES,VLS9000	1
	9	900330A-6005	WASHER,NYLON,1/4IDX1/2ODX0.02TK	1
	8	9650444-0119	MSCR CRES 0.112-40X.38 XRSPNHD	2
	7	9015030-0002	PIN,DOWEL 0.093DIA X 1.00 LG	1
	6	9679500-0000	PLATE,DISK MOUNTING,VLS9000	1
	5	9006221-4405	MSCR CRES 0.112-40X0.25 XRSFLH	2
	4	9679499-0000	DISK,COPPER,VLS9000,2SPNG ALUM	2
G	3	9677347-0000	SHAFT,MAIN,PT9000	1
	2	9679798-0000	SPOOL,CRES,MACHINED,PT9000	1
	1	9604215-0005	SUBASSY,CRES,6 MAGNET,VLS9000	1
ITEM NO.	PART NUMBER	DESCRIPTION	QTY.	

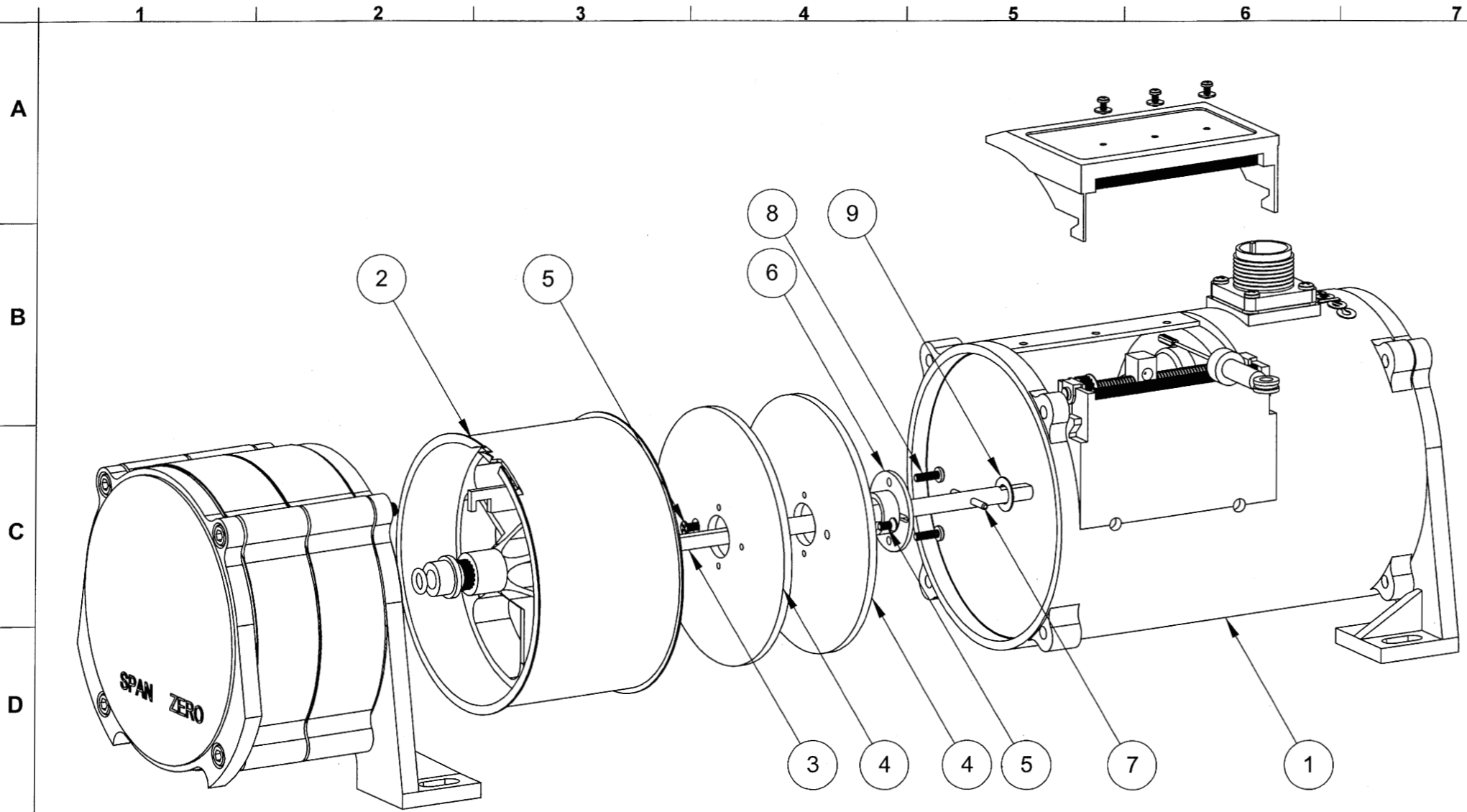
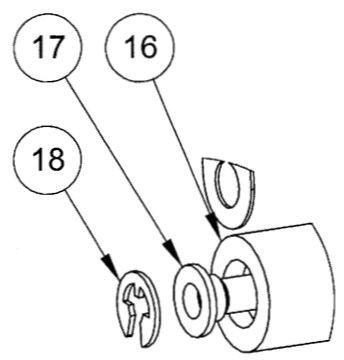

DETAIL A
SCALE 2 : 1

ORIGINAL

INFORMATION AND DATA SET FORTH HEREIN ARE DISCLOSED IN CONFIDENCE AND ARE PROPRIETARY TO AND THE PROPERTY OF CELESCO TRANSDUCER PRODUCTS INC. AND SHALL NOT BE USED, DUPLICATED, DISCLOSED OR TRANSFERRED, IN WHOLE OR IN PART, FOR ANY PURPOSE, WITHOUT THE EXPRESS PRIOR WRITTEN CONSENT OF CELESCO TRANSDUCER PRODUCTS INC.

THIRD ANGLE PROJECTION

celesco
Transducer Products Inc.
20630 Plummer St
Chatsworth, CA. 91311
Tel:(818)701-2750 Fax:(818)701-2799
www.celesco.com

TITLE
**VLS9000 ASSEMBLY DRAWING
CRES,DUAL SPRING**

APPROVALS	DATE	SIZE	CODE IDENT. NO	DWG. NO.	REV
CHKD	2/1/2010	B	52158	PS-167	A

DO NOT SCALE DRAWING SCALE: 1:2 SHEET 1 OF 3

A
B
C
D
E
F
G

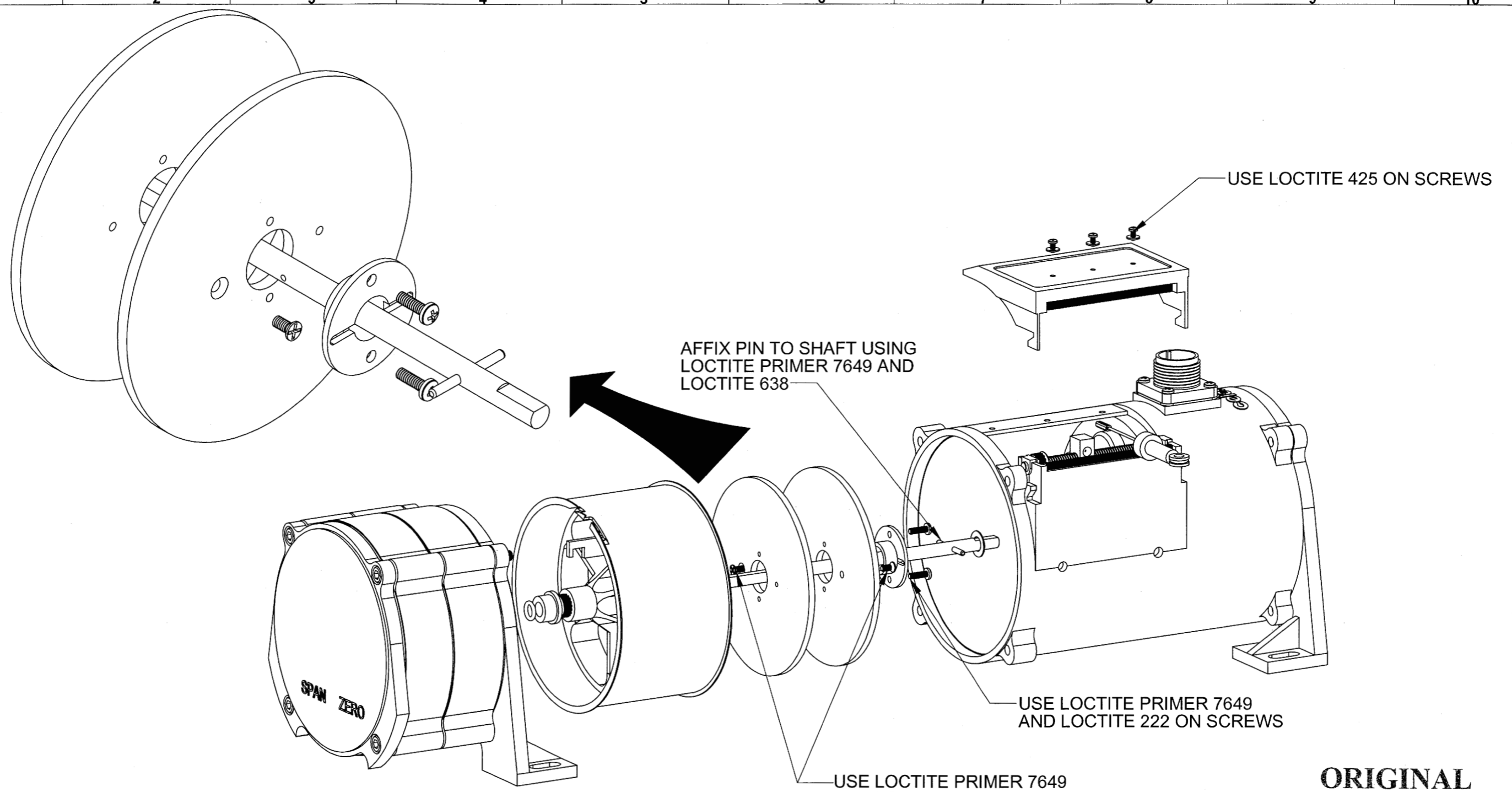

ORIGINAL

2. INSTALL ONE WASHER P/N 900330A-6005 BETWEEN SPOOL AND HOUSING DURING THE BUILDING OF THE TRANSDUCER. AFTER FINAL ASSEMBLY, TEST VELOCITY BY EXTENDING THE CABLE AND RELEASING IT. USE A STOP WATCH TO RECORD THE TIME IT TOOK TO FULLY RETRACT. TO CALCULATE VELOCITY, TAKE THE RANGE OF THE TRANSDUCER AND DIVIDE IT BY THE TIME IT TOOK FOR THE CABLE TO RETRACT.
 - a. IF THE CABLE RETRACTION IS TOO FAST (OVER 80 INCHES PER SECOND), REPLACE .020 THICK WASHER WITH P/N 9000400-0171 (.010 THICK) AND RETRY.
 - b. IF THE CABLE RETRACTION IS TOO SLOW (LESS THAN 40 INCHES PER SECOND), ADD WASHER P/N 9000400-0185 (.005 THICK) AND RETRY.
1. REFER TO PS-119 & PS-127 FOR LOCTITE USAGE AND ASSEMBLY INSTRUCTIONS NOT SHOWN ON THIS DRAWING.

NOTES: UNLESS OTHERWISE SPECIFIED

INFORMATION AND DATA SET FORTH HEREIN ARE DISCLOSED IN CONFIDENCE AND ARE PROPRIETARY TO AND THE PROPERTY OF CELESCO TRANSDUCER PRODUCTS INC. AND SHALL NOT BE USED, DUPLICATED, DISCLOSED OR TRANSFERRED, IN WHOLE OR IN PART, FOR ANY PURPOSE, WITHOUT THE EXPRESS PRIOR WRITTEN CONSENT OF CELESCO TRANSDUCER PRODUCTS INC.

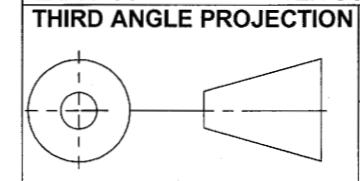

celesco
Transducer Products Inc.
20630 Plummer St
Chatsworth, CA. 91311
Tel:(818)701-2750 Fax:(818)701-2799
www.celesco.com

APPROVALS		DATE	SIZE	CODE IDENT. NO	DWG. NO.	REV
DRAWN E.GARCIA		2/1/2010	B	52158	PS-167	A
CHKD <i>MSL</i>		7/10	DO NOT SCALE DRAWING		SCALE: 1:2	SHEET 2 OF 3

