

TABLE 1

RANGE	CABLE SUB ASSY		CABLE GUIDE OPTIONS			POWER SPRING	
	∅.034	∅.047	BLANK	SS	BR	STANDARD TENSION	INCREASED TENSION
25	9603816-0025	9603862-0025	9676724-0001	9676724-0000	9603673-0000	9676465-0000	9767563-0000
50	9603816-0050	9603862-0050					
625 mm	9603816-0025	9603862-0025					
1250 mm	9603816-0050	9603862-0050					

REVISIONS

REV.	DESCRIPTION	DATE	APPROVED
B	SEE DCN: 6648	11/03/08	MSK

MOUNTING SCREWS AND ALLEN WRENCH TO BE PACKED IN A CLEAR PLASTIC BAG AND ATTACHED TO THE MOUNTING FOOT OF THE TRANSDUCER. IF PT8600 IS ASSEMBLED WITH AN ENCODER, PACKAGE ONLY THE ALLEN WRENCH TO THE FOOT.

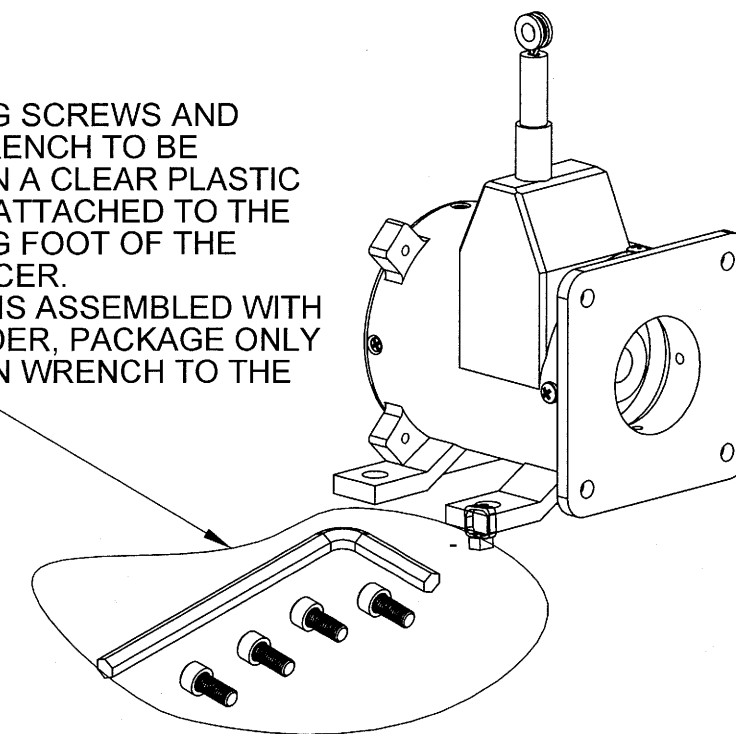

ORIGINAL

ITEM NO.	PART NUMBER	DESCRIPTION	QTY.
13	9011261-6305	SSCR,CRES,0.138-32 X .25 LONG,SKT	2
12	9007121-4405	MSCR CRES 0.112-40X0.25 XRSPNH	4
11	9006221-2505	MSCR CRES 0.086-56X0.25 XRSFLH	4
10	9013112-9901	SPCR,RND,NYLON,0.53 IDX.031THK	1
9	9603816-0125	∅.034 CABLE SUB-ASSEMBLY	1
8	9676724-0001	CBLGUIDE,NYLON RFL,PT8000	1
7	SEE TABLE 2	MOUNTING PLATE,ENCODER,PT8600	1
6	SEE TABLE 1	POWER SPRING, .84 IN-LBS	1
5	9676572-0002	DISK,PHENOLIC,PT8000	1
4	9676572-0001	DISK,PHENOLIC,PT8000	1
3	9604054-0000	SUBASSY,ARBOR-SHAFT ASSY,PT8600	1
2	SEE TABLE 2	SPOOL	1
1	9603620-0001	SUBASSY,PT8600,5 INCH	1

2. REFER TO PS-134 FOR ASSEMBLY DETAILS NOT SHOWN ON THIS DRAWING

1 USE LOCTITE PRIMER 7649 AND LOCTITE 222 ON ALL SCREWS NOTED.

NOTES: UNLESS OTHERWISE SPECIFIED

TABLE 2

MOUNTING OPTION	MOUNTING PLATE	MOUNTING SCREWS	SPOOL RANGE			
			25	50	625	1250
F01	9676901-0000	9650444-0052	9677138-0001	9677138-0010		
F02	9677173-0000	9650444-0054	9677164-0001			
S01	9679636-0000	9650444-0227	9677438-0000	9677438-0005		
S02	9677758-0000	9650444-0009	9677138-0006	9679516-0001		
S04	9677199-0000	9650444-0001				

INFORMATION AND DATA SET FORTH HEREIN ARE DISCLOSED IN CONFIDENCE AND ARE PROPRIETARY TO AND THE PROPERTY OF CELESCO TRANSDUCER PRODUCTS INC. AND SHALL NOT BE USED, DUPLICATED, DISCLOSED OR TRANSFERRED, IN WHOLE OR IN PART, FOR ANY PURPOSE, WITHOUT THE EXPRESS PRIOR WRITTEN CONSENT OF CELESCO TRANSDUCER PRODUCTS INC.

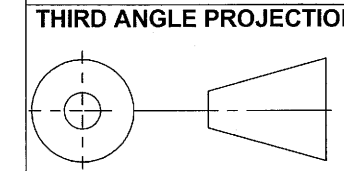

celesco Transducer Products Inc.
20630 Plummer St
Chatsworth, CA. 91311
Tel:(818)701-2750 Fax:(818)701-2799
www.celesco.com

TITLE					
PT8600 ASSEMBLY					
APPROVALS		DATE		SIZE	CODE IDENT. NO
DRAWN M.KRATOFIL		06/04/07		B	52158
CHKD <i>[Signature]</i>		11/6/08		DWG. NO.	REV
				PS-130	B
DO NOT SCALE DRAWING			SCALE: 2:3		SHEET 1 OF 3

REVISIONS			
REV.	DESCRIPTION	DATE	APPROVED
-	See Sheet1	-	-

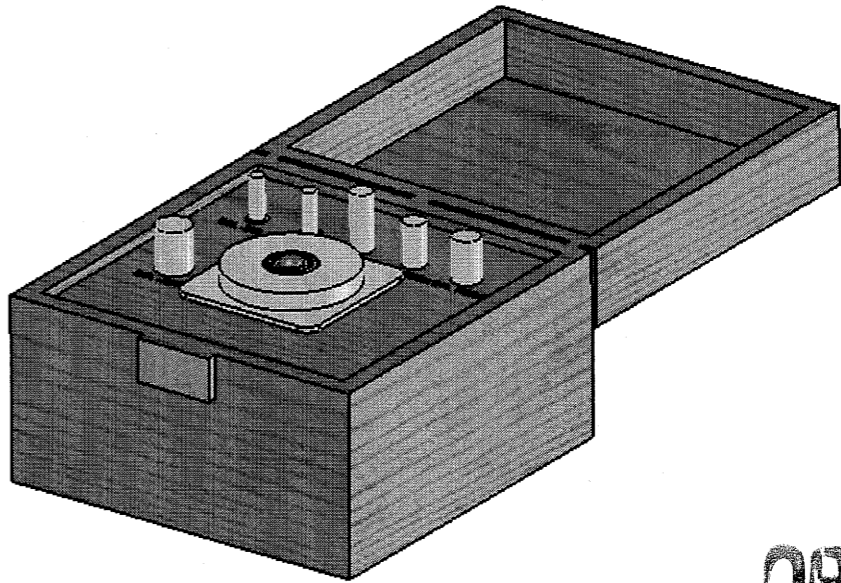
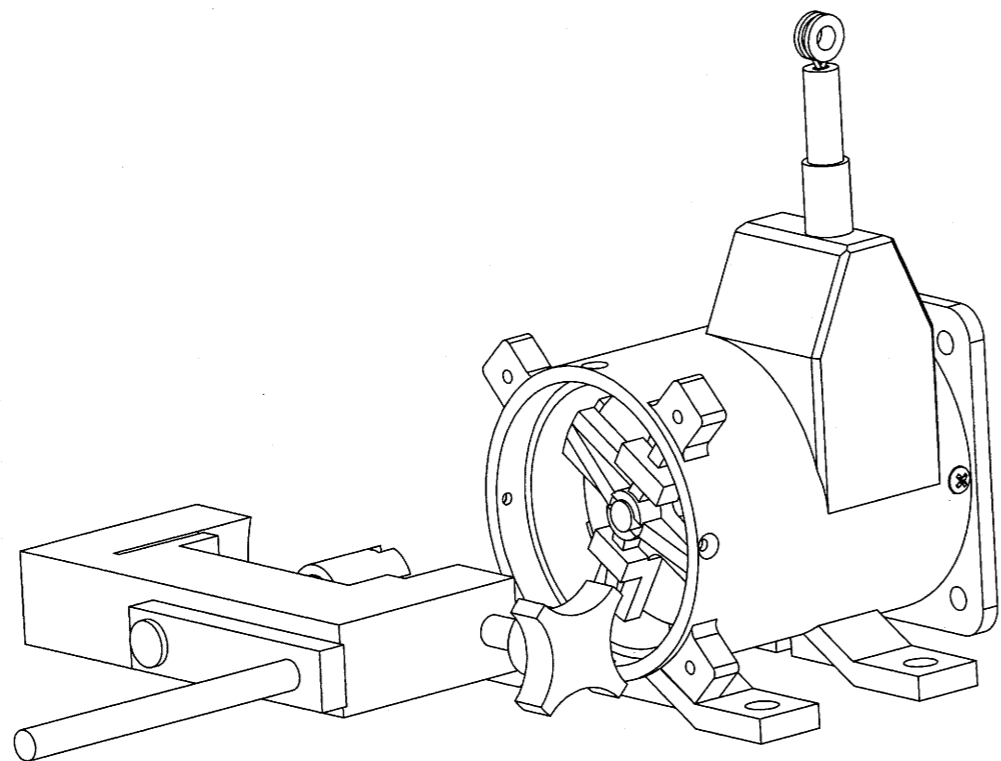

ORIGINAL

SPRING WINDING PROCEDURE:
 BEFORE INSERTING SPOOL INTO HOUSING, ATTACH SPRING WINDING FIXTURE TO THE BODY OF THE PT8600. TIGHTEN FIXTURE SECURELY. WIND THE FIXTURE 27 TURNS. ATTACH CABLE TO SPOOL USING CRIMP AND THREAD SPOOL ONTO MAIN SHAFT. ATTACH EYELET OF CABLE ASSEMBLY TO A FIXED POINT AND RELEASE THE CABLE WINDING FIXTURE. ALLOW CABLE TO RETRACT INTO THE BODY.

IF TRANSDUCER IS BUILT WITHOUT AN ENCODER MOUNTED TO IT, RETRACT CABLE ONTO SPOOL, USING TEST FIXTURE 680322 (SHOWN ABOVE) TO CHECK SMOOTHNESS OF CABLE AND SPRING. REFER TO THE WORK ORDER AND DETERMINE THE SHAFT DIAMETER REQUIRED FOR THE ORDER. REMOVE THE CORRESPONDING DIAMETER PIN AND USING THE FLANGE IN THE BOX ASSEMBLY TO THE PT8600. EXTEND AND RETRACT THE CABLE FULLY SEVERAL TIMES.

INFORMATION AND DATA SET FORTH HEREIN ARE DISCLOSED IN CONFIDENCE AND ARE PROPRIETARY TO AND THE PROPERTY OF CELESCO TRANSDUCER PRODUCTS INC. AND SHALL NOT BE USED, DUPLICATED, DISCLOSED OR TRANSFERRED, IN WHOLE OR IN PART, FOR ANY PURPOSE, WITHOUT THE EXPRESS PRIOR WRITTEN CONSENT OF CELESCO TRANSDUCER PRODUCTS INC.

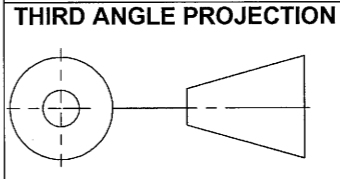

20630 Plummer St
 Chatsworth, CA. 91311
 Tel:(818)701-2750 Fax:(818)701-2799
 www.celesco.com

Transducer Products Inc.
TITLE
PT8600 ASSEMBLY

APPROVALS		DATE	SIZE	CODE IDENT. NO	DWG. NO.	REV
DRAWN	M.KRATOFIL	06/04/07	B	52158	PS-130	B
CHKD	<i>G. Man</i>	4/6/08				
DO NOT SCALE DRAWING			SCALE: 1:4		SHEET 2 OF 3	

